

Mattaponi Sundowners

April 27, 2024

Stages by Ripsaw

Who do you think was the top-rated Western movie star, according to a recent poll?

Jimmy Stewart? John Wayne? Clint Eastwood? Gary Cooper? Yul Brynner? Franco Nero?

These are the top six.

As these stages play out, you'll discover how they ranked. Stages 1 through 6 will reveal the rankings, First Place through Sixth Place.

Stages 1-3 Diagram

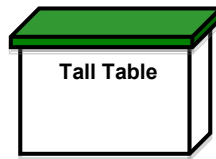
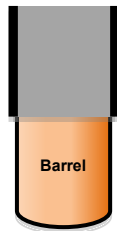
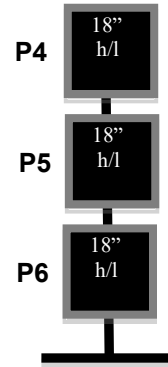
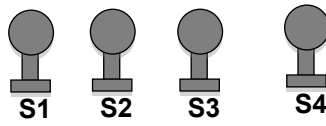
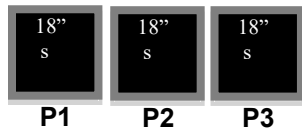
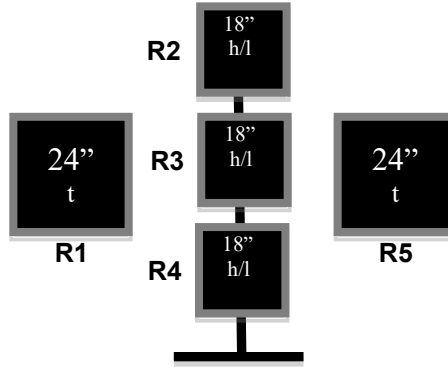

STAGE: 1

RC/SO: Shotgun 4+, Rifle-10, Pistols-5 each,

Pistols holstered, Rifle and Shotgun staged on the tall table.

Shooter starts standing at the tall table at default. When ready, the shooter says, "Clint Eastwood was first of course!" At the beep, with shotgun, shoot the four knockdowns, S1-S4 in any order. Next, with rifle, shoot the three (horizontal row) rifle targets, R1, R3, R5 with a double tap Nevada Sweep, starting on either end. For example, R1, R1, R3, R3, R5, R5, R3, R3, R1, R1. Last, move to the barrel and with pistols, shoot the pistol targets P1-P3 with the same instructions as the rifle.

STAGE: 2

RC: Rifle-10, Shotgun- 4+, Pistols-5 each

SO: Rifle not last

Pistols holstered, Rifle staged on the Tall Table, Shotgun staged safely

Shooter starts at default. When ready, shooter says "John Wayne was a close second!" At the beep, shoot:

1. From the Tall table, with rifle, the three (vertical row) rifle targets R2, R3, R4 with a 2-1-2 sweep from the top down and then a 2-1-2 sweep from the bottom up. For example, R2, R2, R3, R4, R4, R4, R4, R3, R2, R2.
2. From the Horse, with pistols, targets P4-P6 with the same instructions as rifle.
3. From the tall table, with shotgun, shoot S1-S4 in any order.

STAGE: 3

RC/SO: Rifle-10, Pistols-5 each, Shotgun 2+

Pistols holstered, Rifle held at cowboy port arms, Shotgun staged safely

Shooter starts standing at the Tall Table with rifle at cowboy port arms. When ready, the shooter says, "Gary Cooper was third?" At the beep, with rifle, shoot R1-R5, with 10 rounds in any order, all targets engaged. Next, move to either the barrel or the horse and with pistols, shoot the pistol targets at that location with 5 shots in any order, all targets engaged. Next, move to the other pistol target position and repeat instructions. Last, return to the Tall Table and with shotgun, shoot any two of S1-S4 in any order.

Stages 4-6 Diagram

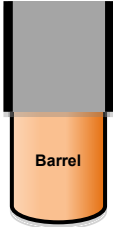
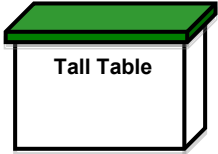
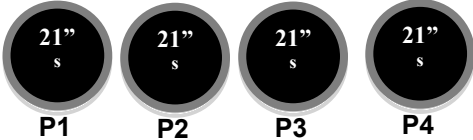
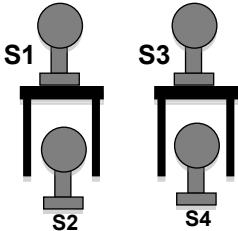
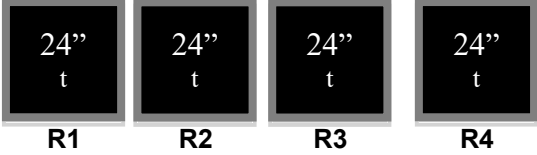

STAGE: 4

RC/SO: Rifle-10, Shotgun- 4+, Pistols-5 each,

Pistols holstered, Rifle pointed safely downrange, shotgun staged safely

Shooter starts standing at the Tall Table with Rifle pointed safely downrange. When ready, shooter says, “How did Jimmy Stewart even make this list?” At the beep, with rifle, shoot the 4 rifle targets, R1-R4 As follows: R1, R2, R3, R4, R3, R3, R2, R2, R1, R1. Then, with Shotgun, shoot the four knockdowns, S1-S4 as follows: bottom, top, bottom, top. Then, move to the barrel and with pistols, shoot the 4 pistol targets, P1-P4 with the same instructions as the rifle.

STAGE: 5

RC/SO: Pistols-5 each, Rifle-10, Shotgun 6+

Pistols holstered, Rifle and shotgun staged on the tall table.

Shooter starts standing at the barrel with hands on pistol or pistols. When ready, shooter says, “Yul Brynner wasn’t much of a cowboy!” At the beep, shoot the 4 pistol targets, P1-P4 with a progressive sweep, starting on either end target. For example, P1, P2, P2, P3, P3, P4, P4, P4, P4. Then move to the tall table and with rifle, shoot the four rifle targets, R1-R4 with the same instructions as pistols. Last, with shotgun, shoot some (but not all!) (one, two or three of them) of the 4 knockdowns, S1-S4. Move to horse with a safe shotgun and shoot one (1) of the knockdowns, S5 or S6. Return to the tall table with safe shotgun and shoot the remaining knockdown(s). Finally, return again to the horse and shoot the remaining knockdown.

STAGE: 6

RC: Rifle-10, Shotgun, 6+, Pistols-5 each

SO: Rifle not last

Pistols holstered, Rifle staged on the Tall Table, Shotgun staged safely

Starting at default, when ready, shooter says, “Who the heck was Franco Nero?!” At the Beep:

1. With rifle, from the Tall Table, shoot the four rifle targets, R1-R4 as follows: R1, R1, R2, R2, R3, R3, R4, R4, R1, R4.
2. With shotgun from the Tall Table, shoot S1-S4 in any order.
3. From the Barrel, with pistols, shoot P1-P4 with same instructions as rifle.
4. From horse, with shotgun, shoot S5 and S6 in any order.