

The Mattaponi Sundowners

Sunday - May 15th, 2016

"Pecos Bill Rides a Tornado"

Stages Written by: Striker

Now everyone in the West knows that Pecos Bill could ride anything. No bronco could throw him, no sir! Fact is, I only heard of Bill getting' throwed once in his whole career as a cowboy. Yep, it was that time he was up Kansas way and decided to ride him a tornado.

Now Bill wasn't gonna ride jest any tornado, no ma'am. He waited for the biggest gol-durned tornado you ever saw. It was turning the sky black and green, and roaring so loud it woke up the farmers away over in China. Well, Bill jest grabbed that there tornado, pushed it to the ground and jumped on its back. The tornado whipped and whirled and sidewinded and generally cussed its bad luck all the way down to Texas. Tied the rivers into knots, flattened all the forests so bad they had to rename one place the Staked Plains. But Bill jest rode along all calm-like, give it an occasional jab with his spurs.

Finally, that tornado decided it wasn't getting this cowboy off its back no-how. So it headed west to California and jest rained itself out. Made so much water it washed out the Grand Canyon. That tornado was down to practically nothing when Bill finally fell off. He hit the ground so hard it sank below sea level. Folks call the spot Death Valley.

Anyway, that's how rodeo got started. Though most cowboys stick to broncos these days.

The Mattaponi Sundowners

Sunday – May 15th, 2016

Mattaponi Sundowners – Rules and Stage Conventions

- Revised 04-24-2013 -

- **SASS Rules:** All SASS Rules are in affect; unless documented here, address during the Shooter Safety Meeting or specifically stated in the stage description for a given stage.
- **Round Over Berm:** A round fired over the berm is a Match DQ, excluding shotguns.
- **“No Alibi”:** All matches at Mattaponi are “no alibi” matches. *“Once the first round goes down range, the competitor is committed to the stage and must finish the stage to the best of his or her ability. Reshoots/restarts are not awarded for ammunition or firearm malfunctions. However, if there is a range failure (failure of props, timer, or the range officers) beyond the competitor’s control, a restart may be granted. On a reshoot/restart, the competitor starts over clean, carrying only accrued safety penalties forward. Restarts shall be allowed for a competitor to achieve a “clean” start up to the point at which the first round goes down range. Multiple restarts by the same shooter, that in the judgment of the R.O. are seen to be taking advantage, will not be entertained as they are not in the spirit of the game.”*
- **SASS Stage Conventions:** Unless specifically stated in the stage description for a given stage, all SASS Stage Conventions are in affect.
- **Shotgun Knockdown Misses:** Unless specifically stated in the stage description for a given stage and pursuant to SASS rules, all shotgun knockdown targets may be reengaged until down, aka “Comstock Rule”.
- **Loading on the Move:** Loading on the move is permitted pursuant to SASS rules.
- **Drawing on the Move:** Drawing on the move is permitted pursuant to SASS rules.
- **Muzzle Position:** When there is a risk of a prop blocking the muzzle of a firearm, the muzzle must be positioned downrange of the prop, as determined by the Range Officer. For example: shooting through the window of a store front or shooting beside a wall.
- **End of Stage:** Unless otherwise directed by a Range Officer, after a stage has been completed the shooter will safely retrieve rifle, shotgun, and pistols and move them to the unloading table. The shooters firearms will not leave the unloading table until they have been verified “cleared” by a Range Officer.
- **Coaching:** Any shooter who wishes to not receive coaching must state their preference at the beginning of each stage. The Mattaponi Sundowners strongly believe that shooters helping shooters (coaching) is a critical component of the “Cowboy Way” and part of what makes this game great!! Therefore coaching is strongly encouraged and supported.

The Spotters Creed:

If you know that it’s a Hit...It’s a Hit

If you know that it’s a Miss...It’s a Miss

If you think it’s a Hit...It’s a Hit

If you think it’s a Miss...IT’S A HIT

Benefit of the doubt always goes to the shooter

The Mattaponi Sundowners

Sunday - May 15th, 2016

STAGE ONE (Bay #2)

Round Count: 10 pistol, 10 rifle, 6+ shotgun

Shooting Order: Rifle, Shotgun, Pistols or Pistols, Rifle, Shotgun

Staging: Rifle is loaded with 10 rounds and staged safely. Both pistols are loaded with 5 rounds each and holstered. Shotgun is staged safely.

Procedure: Shooter starts at Position 1 or Position 2 with hands on head/hat and when ready says "Pecos Bill Rides a Tornado". At the beep: From Position 1 with rifle engage the ten rifle targets (R1 thru R10) with single taps, all targets engaged, in any order. Next with shotgun engage the six knockdown targets (S1 thru S6) in any order. From Position 2 with pistols engage the five pistol targets (P1 thru P5) with two shots each, all targets engaged, in any order.

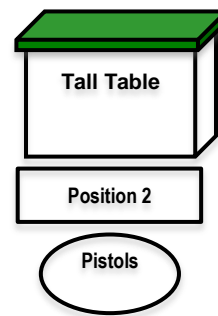
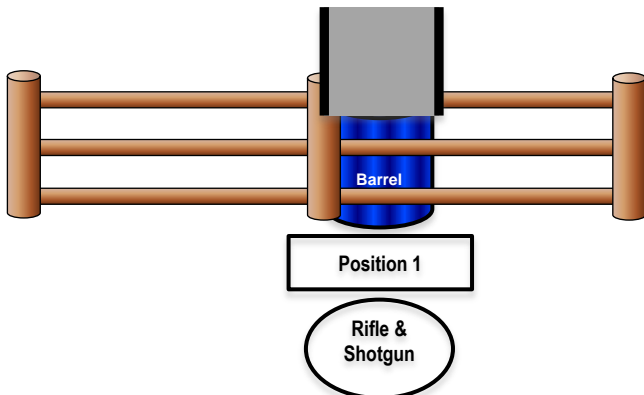
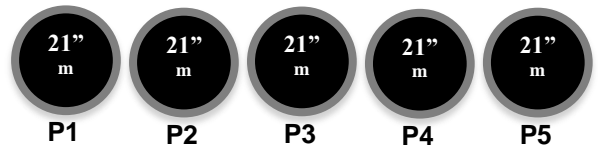
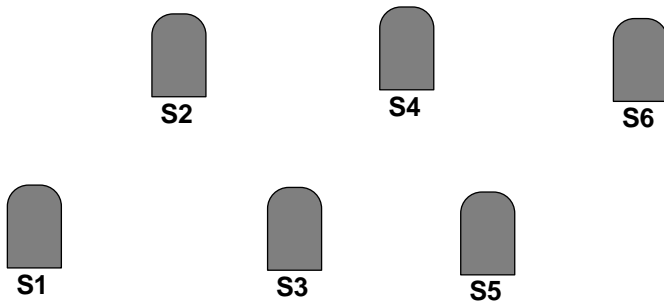
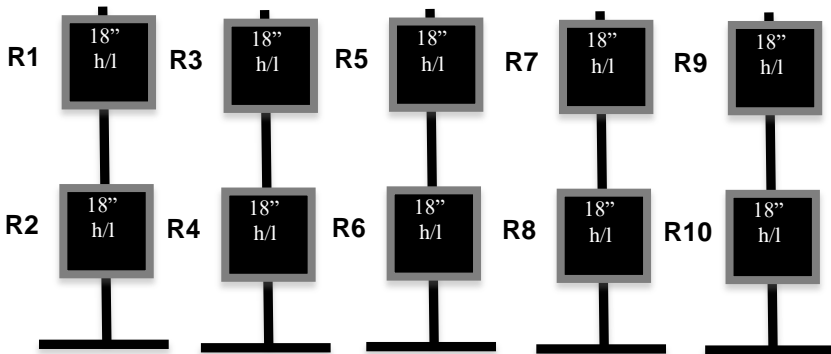

The Mattaponi Sundowners

Sunday - May 15th, 2016

STAGE TWO (Bay #2)

Round Count: 10 pistol, 10 rifle, 6+ shotgun

Shooting Order: Rifle, Shotgun, Pistols or Pistols, Rifle, Shotgun

Staging: Rifle is loaded with 10 rounds and staged safely. Both pistols are loaded with 5 rounds each and holstered. Shotgun is staged safely.

Procedure: Shooter starts at Position 1 or Position 2 with hands clasped together and when ready says "Pecos Bill Rides a Tornado". At the beep: From Position 1 with rifle engage the ten rifle targets (R1 thru R10) by engaging both targets in a column in the following column order (middle, inside, other inside, outside, other outside). Next with shotgun engage the six knockdown targets (S1 thru S6) in any order. From Position 2 with pistols engage the five pistol targets (P1 thru P5) with double taps in the following order (middle, inside, other inside, outside, other outside).

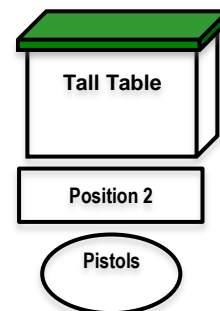
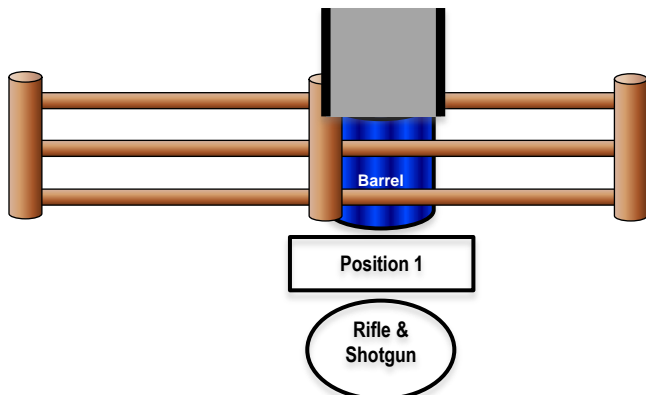
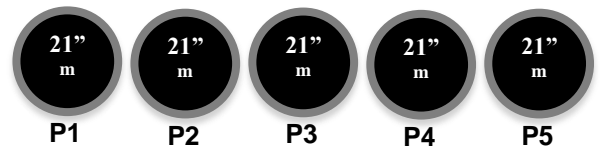
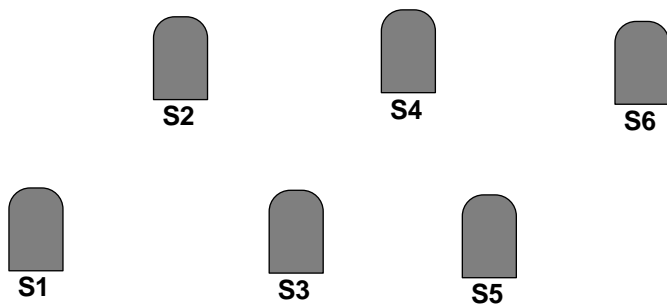
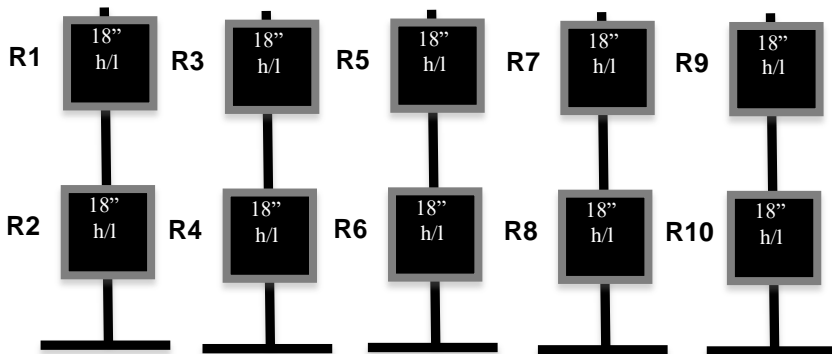

The Mattaponi Sundowners

Sunday - May 15th, 2016

STAGE THREE (Bay #2)

Round Count: 10 pistol, 10 rifle, 2+ shotgun

Shooting Order: Rifle, Shotgun, Pistols or Pistols, Rifle, Shotgun

Staging: Rifle is loaded with 10 rounds and staged safely. Both pistols are loaded with 5 rounds each and holstered. Shotgun is staged safely.

Procedure: Shooter starts at Position 1 or Position 2 with first gun(s) pointed down range and when ready says "Pecos Bill Rides a Tornado". At the beep: From Position 1 with rifle engage the ten rifle targets (R1 thru R10) by sweeping five targets in one direction and then sweeping the other five targets in the opposite direction. Next with shotgun engage any two of the six knockdown targets (S1 thru S6) in any order. From Position 2 with pistols engage the five pistol targets (P1 thru P5) by sweeping the five targets in one direction and then sweeping the five targets in the opposite direction.

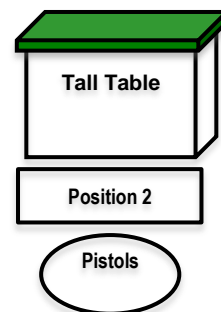
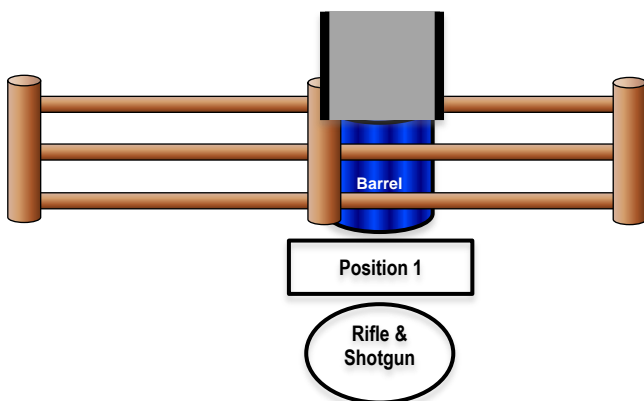
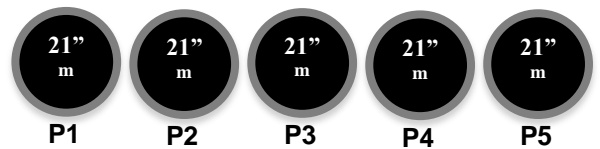
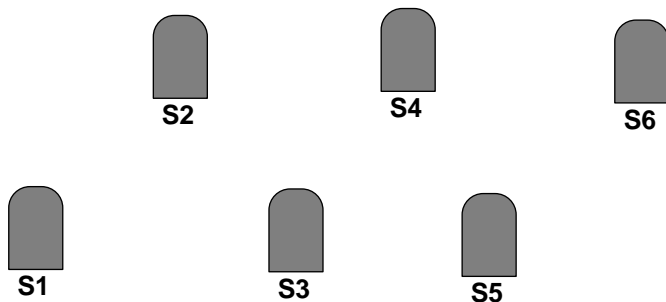
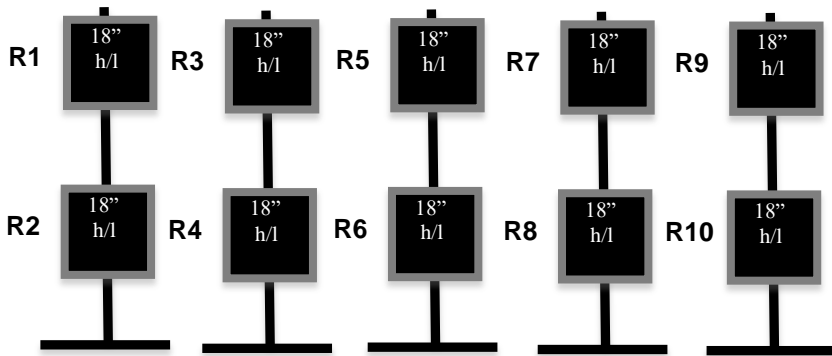

The Mattaponi Sundowners

Sunday - May 15th, 2016

STAGE FOUR (Bay #3)

Round Count: 10 pistol, 10 rifle, 6+ shotgun

Shooting Order: Shotgun, Rifle, Pistols, Shotgun

Staging: Rifle is loaded with 10 rounds and staged safely. Both pistols are loaded with 5 rounds each and holstered. Shotgun is staged safely.

Procedure: Shooter starts at Position 1 or Position 3 with shotgun at cowboy port arms and when ready says "Pecos Bill Rides a Tornado". At the beep: From Position 1 with shotgun engage the three knockdown targets (S1 thru S3) in any order. From Position 2 with rifle engage the five rifle targets (R1 thru R5) in a 1-1-6-1-1 sweep. Next with pistols engage the five pistol targets (P1 thru P5) in a 1-1-6-1-1 sweep. From Position 3 with shotgun engage the three knockdown targets (S4 thru S6) in any order.



Bonus

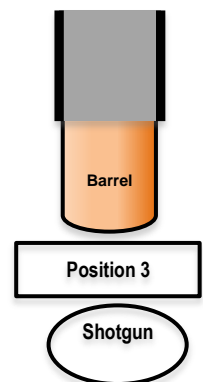
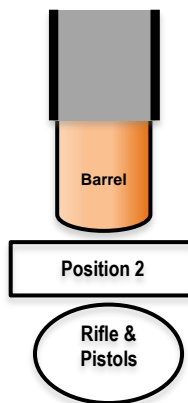
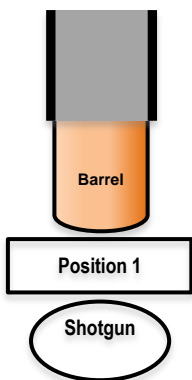
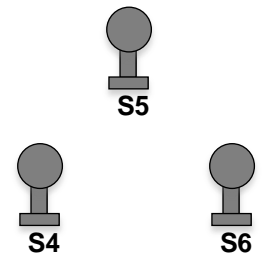
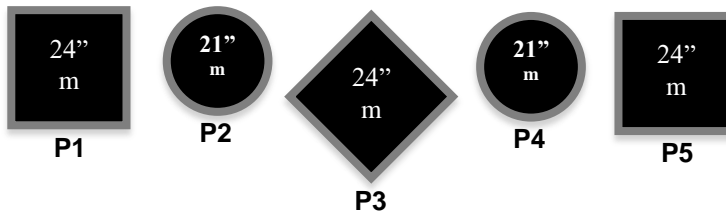
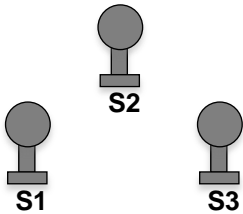
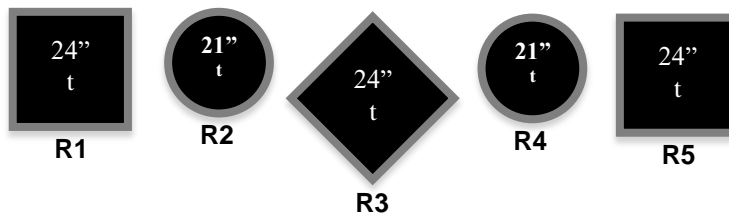

The Mattaponi Sundowners

Sunday - May 15th, 2016

STAGE FIVE (Bay #3)

Round Count: 10 pistol, 10+1 rifle, 4+ shotgun

Shooting Order: Rifle, Shotgun, Pistols, Shotgun or Shotgun, Pistols, Rifle, Shotgun

Staging: Rifle is loaded with 10 rounds and staged safely. Both pistols are loaded with 5 rounds each and holstered. Shotgun is staged safely.

Procedure: Shooter starts at Position 1 or Position 3 in the default position and when ready says "Pecos Bill Rides a Tornado". At the beep: From Position 1 with rifle engage the five rifle targets (R1 thru R5) by sweeping the five targets and then engage the middle three targets in a Nevada Sweep starting on the middle target, for example (R1, R2, R3, R4, R5, R3, R4, R3, R2, R3). Next with rifle reload engage the bonus target for a 5 second bonus. Rifle reload may take place any time after the beep, misses do not count on bonus target. Next with shotgun engage any two of the three knockdown targets (S1 thru S3) in any order. From Position 2 with pistol engage the five pistol targets (P1 thru P5) by sweeping the five targets and then engage the middle three targets in a Nevada Sweep starting on the middle target. From Position 3 with shotgun engage any two of the three knockdown targets (S4 thru S6) in any order.

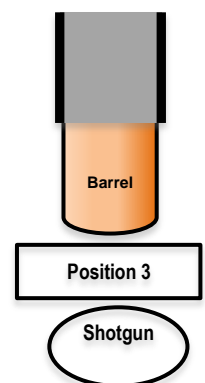
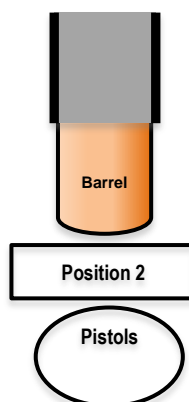
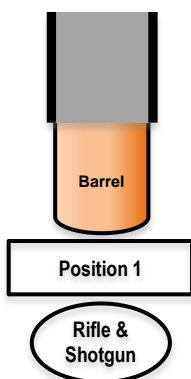
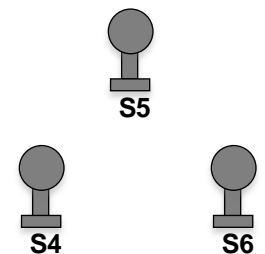
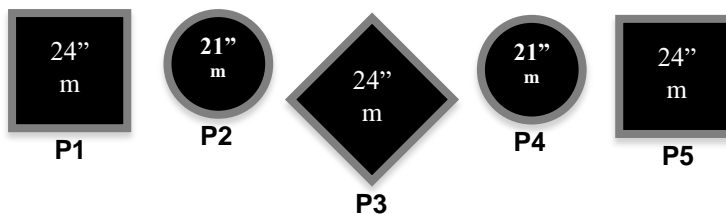
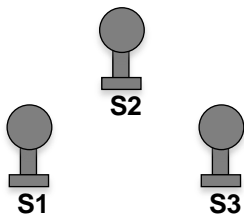
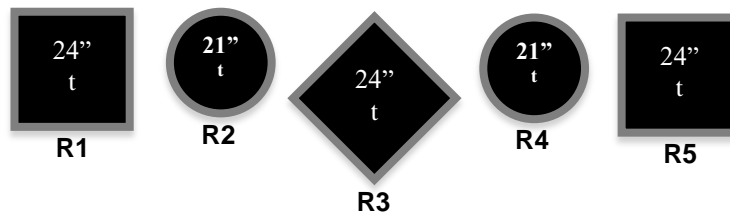

The Mattaponi Sundowners

Sunday - May 15th, 2016

STAGE SIX (Bay #3)

Round Count: 10 pistol, 10 rifle, 6+ shotgun

Shooting Order: Shotgun, Shotgun, Rifle, Pistols

Staging: Rifle is loaded with 10 rounds and staged safely. Both pistols are loaded with 5 rounds each and holstered. Shotgun is staged safely.

Procedure: Shooter starts at Position 1 or Position 3 with shotgun pointed down range and when ready says "Pecos Bill Rides a Tornado". At the beep: From the start position engage the three shotgun knockdown targets (S1 thru S3) or (S4 thru S6) in any order. Move to the other start position. Next with shotgun engage the three shotgun knockdown targets (S1 thru S3) or (S4 thru S6) in any order. Move to Position 2. Next with rifle engage the five rifle targets (R1 thru R5) with a double tap sweep. Last with pistols engage the five pistol targets (P1 thru P5) with a double tap sweep.

